



DESCRIPTION

The basic VM12, made entirely of AISI304 stainless steel, equipped with a digital control panel, stands out for its extreme robustness, ease of use and compactness. Its versatility makes it possible to package the products in the chamber, in external containers via the suction device and in embossed envelopes outside the chamber. The quality and proven reliability of the machine and its components derives from the over twenty-year widespread presence on the global market, in all areas and all sectors.



SEALING BAR 10,6 inch
VACUUM PUMP 282 cf/h
SENSOR CONTROL

FEATURES

- Oil lubricated rotary vane vacuum pump, nominal speed 282 cf/h (8 m³/h);
- Vacuum level control through high precision sensor;
- Maximum vacuum 99.8% (2 millibars);
- 10,6" sealing bar, easily removable for cleaning;
- Removable sealing bar lifting device, with sealing cap for cleaning
- Digital control panel with 7 keys and 3 digit display;
- 10 editable programs;
- Program for vacuum packaging ("Jars"-key) in containers;
- Adjustable sealing intensity;
- Pump oil dehumidification program;
- Resettable oil change alarm;
- Analog vacuum gauge for displaying the vacuum level
- AISI304 Stainless steel hydroformed vacuum chamber with constant thickness;
- AISI304 Stainless steel bodywork; pump oil drain of the machine body equipped with cover, which prevents the penetration of impurities or insects inside the machine;
- High-thickness blued PMMA (Plexiglass) lid with polished and rounded edges; opens automatically at the end of the cycle;
- Chromed aluminum die-cast hinges;
- Thermal welding protection system;
- Accessory "Easy" for external vacuum in embossed bags;
- 3 PE-filling plates for product adjustment and cycle speed up;

OPTIONALS

- Inert gas injection;

ACCESSORIES

- Bags for storage, cooking and "cook & chill"; embossed bags;
- Stainless steel cart with castors and shelf;
- Inclined stainless steel plate for liquid packing;
- Suction device for external containers;



Intertek Intertek

According to:
UL197 / NSF Hygienic standards

PROJECT	DATE	APPROVED
ITEM	QTY	

VACUUM PACKAGING MACHINES VM12

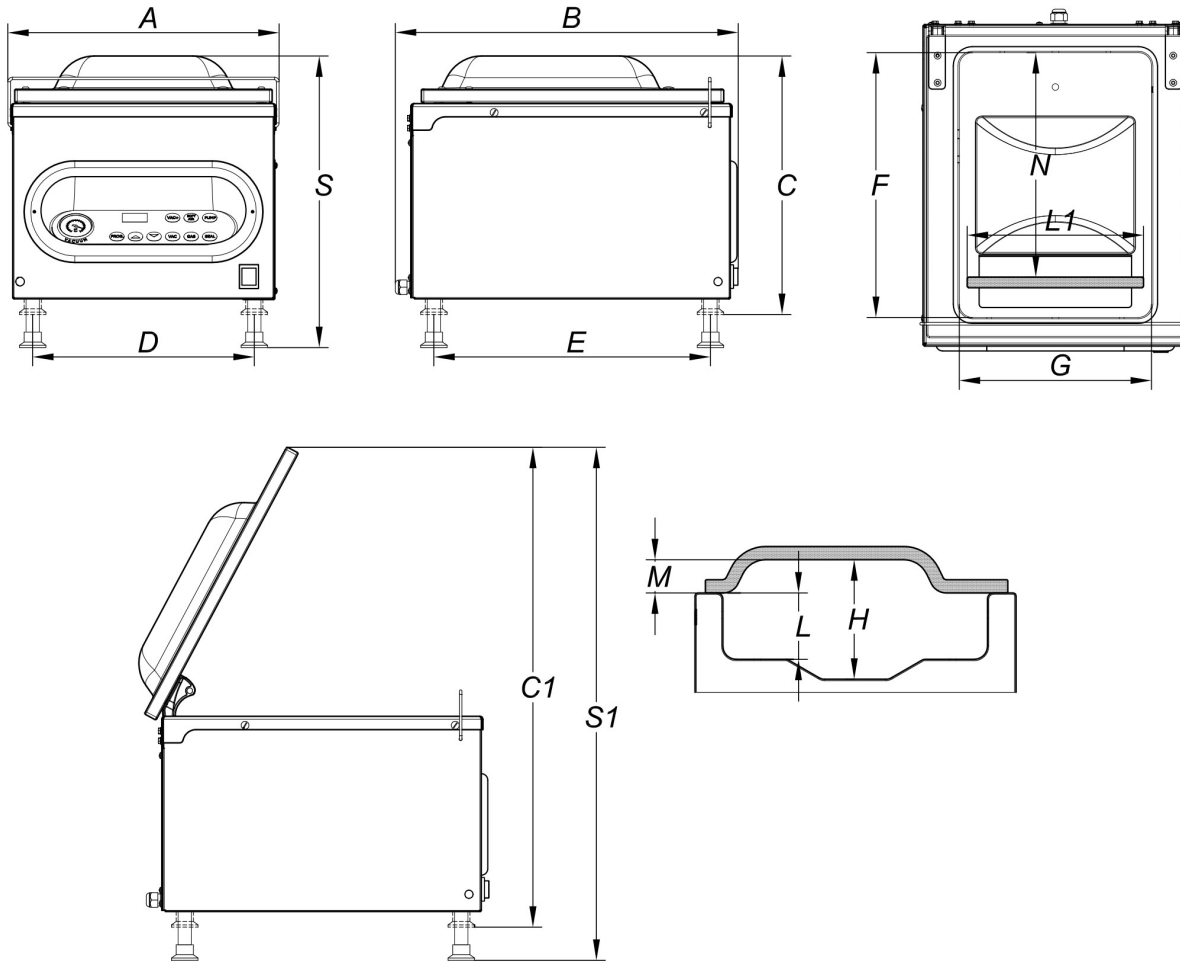

SPECIFICATIONS

Length of seal L1	inch	10,6
Nominal pump speed	cf/h	282
Final pressure	mbar	2
Chamber size (FxGxH)	inch	15,7x11,4x7,1
Useful chamber space (N)	inch	13,3
Chamber depth (L)	inch	3,9
Chamber volume	Usgal	3,96
Power	W	620
Electrical voltage/Frequency/Phases	V/Hz	110V / 60Hz / 1Ph+N+PE
Power cord and plug		82,6 inch / Nema 5
Current	A	5,63
Housing materials		AISI304
Vacuum chamber material		AISI304
Lid material		PMMA (Plexiglas)
Overall dimensions (AxBxC)	inch	16,1x20,4x15,3
Overall dimensions (AxBxS)	inch	16,1x20,4x17,3
Maximum height with open lid (S1)	inch	30,4
Maximum height with open lid (C1)	inch	28,5
Distance between supports (DxE)	inch	13,1x16,4
Weight (with filling plates)	lbs	88,2
Noise level	dB(A)	58
Environmental operating temperature (min-max)	°F	53,6-104